

Three Phase Electric Motors-Cast iron Frame - PM3C250M6-B3

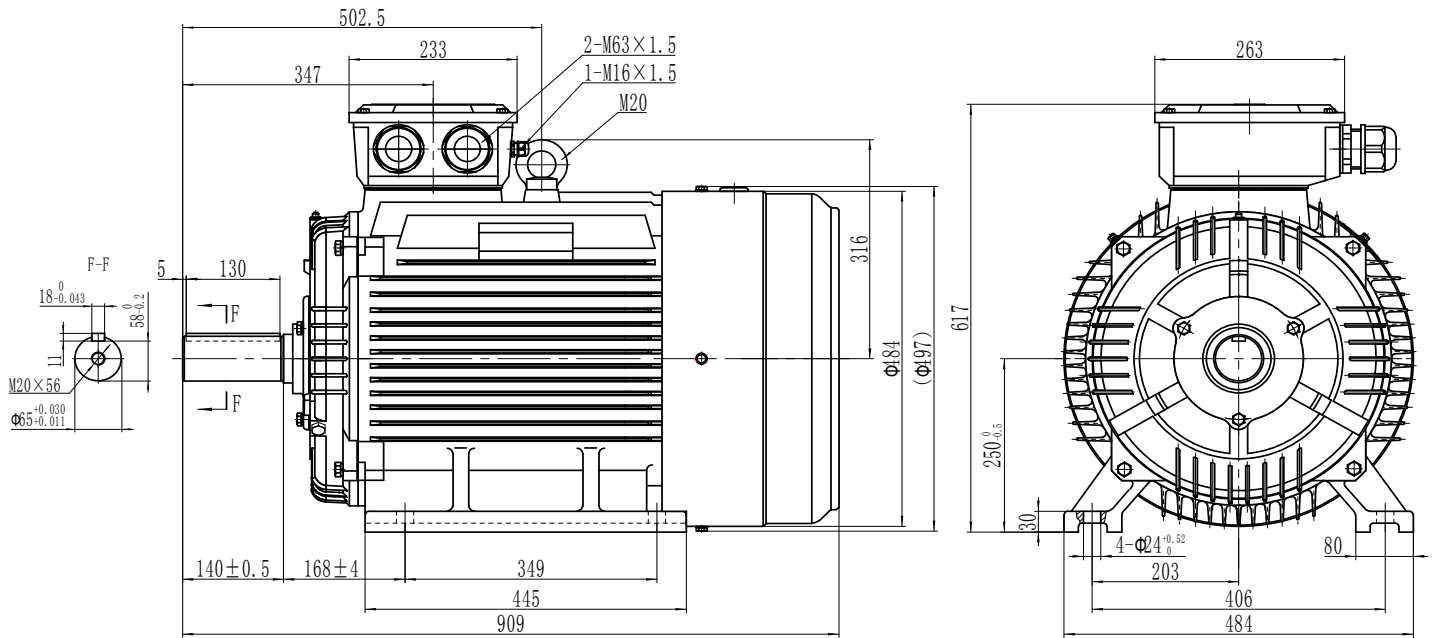

Type	PM3C250M6-B3
Frame Size	250M
Capacity	37kW
Speed / Pole	980 RPM / 6 Pole
Mounting Position	IMB3
Insulation Class	F
Protection Class	IP55
Duty Cycle	S1 Continuous
Temperature Rise Class	B
Ambient temp. (°C)	45°C
Cooling method	IC411 self-Ventilated

Efficiency	IE3 Premium Efficiency
Power Factor COS (phi)	84%
I-starting / I-nominal	7.0
T-starting / T-nominal	2.35
T-max/Tn	2.36
Full Load Torque	358.9Nm
Thermal protection	PTC thermistor
Noise	72dB
Bearing DE	SKF 6314
Bearing NDE	SKF 6313
Weight (kg)	398

Electrical data:

Rated Power (kW)	37	35.9	44.4	43.1			
Frequency (Hz)	50	50	60	60			
Voltage (V)	400	690	380	660	480	830	440
Speed (RPM)	980	980	980	980	1175	1175	1175
Connection	Δ	Y	Δ	Y	Δ	Y	Δ
Full load current (A)	68.1	39.3	69.9	68.1	39.3	56.3	69.9