

Three Phase Electric Motors-Cast iron Frame - PM3C160MB2-B35

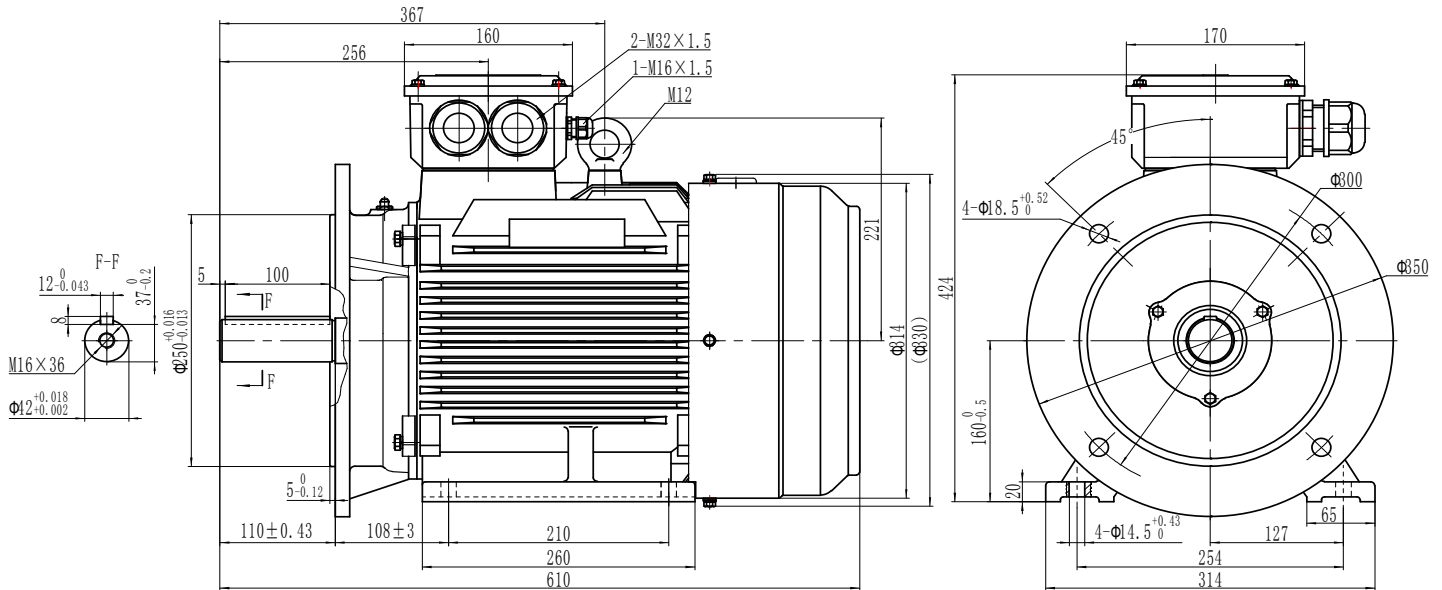

| | |
|------------------------|-----------------------|
| Type | PM3C160MB2-B35 |
| Frame Size | 160M |
| Capacity | 15 kW |
| Speed / Pole | 2930 RPM / 2 Pole |
| Mounting Position | IMB35 |
| Insulation Class | F |
| Protection Class | IP55 |
| Duty Cycle | S1 Continuous |
| Temperature Rise Class | B |
| Ambient temp. (°C) | 45°C |
| Cooling method | IC411 self-Ventilated |

| | |
|------------------------|------------------------|
| Efficiency | IE3 Premium Efficiency |
| Power Factor COS (phi) | 89% |
| I-starting / I-nominal | 9.9 |
| T-starting / T-nominal | 2.95 |
| T-max/Tn | 3.9 |
| Full Load Torque | 48.5Nm |
| Thermal protection | PTC thermistor |
| Noise | 79.4 dB |
| Bearing DE | SKF 6209 |
| Bearing NDE | SKF 6209 |
| Weight (kg) | 140 |

Electrical data:

| | | | | | | | |
|-----------------------|----------|------|----------|------|----------|------|----------|
| Rated Power (kW) | 15 | 14.6 | 18 | 17.5 | | | |
| Frequency (Hz) | 50 | 50 | 60 | 60 | | | |
| Voltage (V) | 400 | 690 | 380 | 660 | 480 | 830 | 440 |
| Speed (RPM) | 2930 | 2930 | 2930 | 2930 | 3510 | 3510 | 3510 |
| Connection | Δ | Y | Δ | Y | Δ | Y | Δ |
| Full load current (A) | 26.5 | 15.3 | 27.3 | 15.7 | 26.5 | 15.3 | 27.3 |