

Three Phase Electric Motors-Cast iron Frame - PM3C160MB2-B3

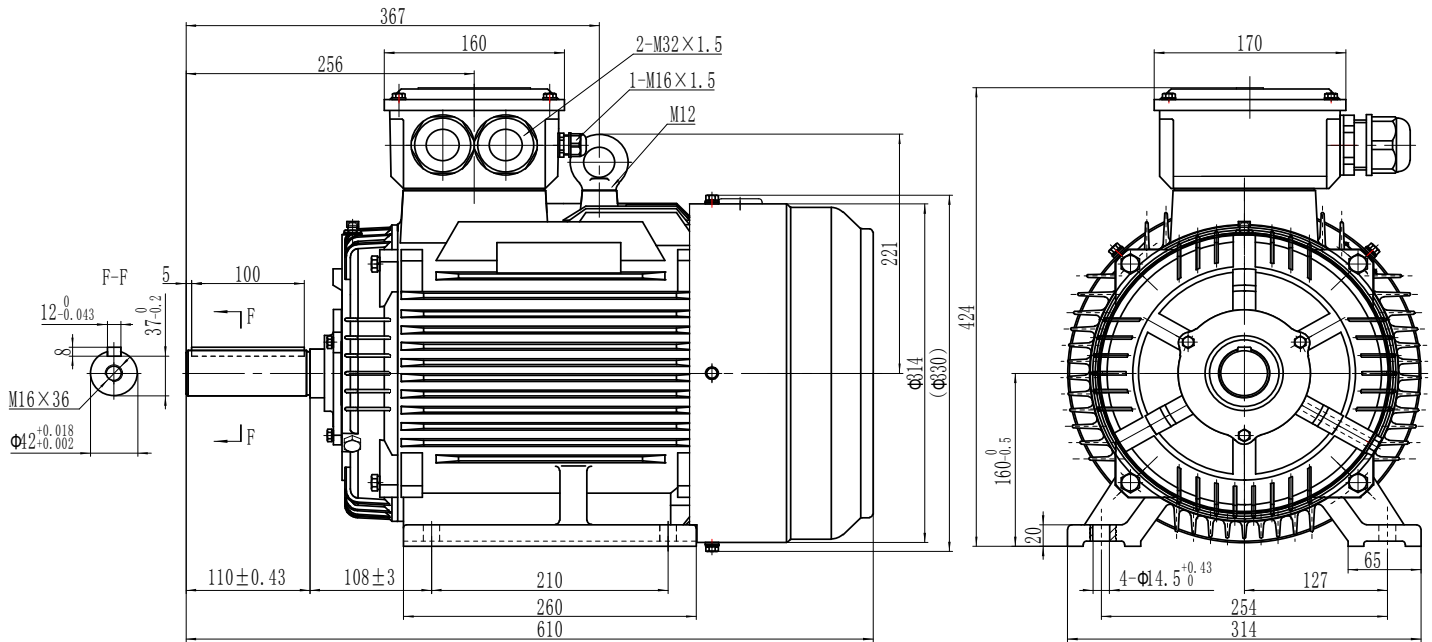

Type	PM3C160MB2-B3
Frame Size	160M
Capacity	15 kW
Speed / Pole	2930 RPM / 2 Pole
Mounting Position	IMB3
Insulation Class	F
Protection Class	IP55
Duty Cycle	S1 Continuous
Temperature Rise Class	B
Ambient temp. (°C)	45°C
Cooling method	IC411 self-Ventilated

Efficiency	IE3 Premium Efficiency
Power Factor COS (phi)	89%
I-starting / I-nominal	9.9
T-starting / T-nominal	2.95
T-max/Tn	3.9
Full Load Torque	48.5Nm
Thermal protection	PTC thermistor
Noise	79.4 dB
Bearing DE	SKF 6209
Bearing NDE	SKF 6209
Weight (kg)	137

Electrical data:

Rated Power (kW)	15	14.6	18	17.5			
Frequency (Hz)	50	50	60	60			
Voltage (V)	400	690	380	660	480	830	440
Speed (RPM)	2930	2930	2930	2930	3510	3510	3510
Connection	Δ	Y	Δ	Y	Δ	Y	Δ
Full load current (A)	26.5	15.3	27.3	15.7	26.5	15.3	27.3